

LMCB24-SR(-T)

Proportional, Non-Spring Return, 24 V, for 2 to 10 VDC or 4 to 20 mA



Technical Data	LMCB24-SR(-T)
Power supply	24 VAC \pm 20% 50/60 Hz 24 VDC \pm 10%
Power consumption	1.5 W (0.4 W)
Transformer sizing	3 VA (Class 2 power source)
Electrical connection	3 ft, 18 GA plenum rated cable 1/2" conduit connector protected NEMA 2 (IP54)
Overload protection	electronic throughout 0 to 95° rotation
Operating range Y	2 to 10 VDC, 4 to 20 mA
Input impedance	100 k Ω (0.1 mA), 500 Ω
Feedback output U	2 to 10 VDC (max 0.5 mA)
Angle of rotation	max. 95°, adjustable with mechanical stop
Torque	45 in-lb [5 Nm]
Direction of rotation	reversible with switch actuator will move: =CCW with decreasing control signal (10 to 2V) =CW with decreasing control signal (10 to 2V)
Position indication	reflective visual indicator (snap-on)
Manual override	external push button
Running time	35 seconds, constant independent of load
Humidity	5 to 95% RH non condensing (EN 60730-1)
Ambient temperature	-22°F to 122°F [-30°C to 50°C]
Storage temperature	-40°F to 176°F [-40°C to 80°C]
Housing	NEMA 2, IP54, UL enclosure type 2
Housing material	UL94-5VA
Agency listings†	cULus acc. to UL 60730-1A/-2-14, CAN/CSA E60730-1:02, CE acc. to 2004/108/EEC and 2006/95/EC
Noise level	<45dB(A)
Servicing	maintenance free
Quality standard	ISO 9001
Weight	1.1 lbs [0.5 kg]

LMCB24-SR-T	
Electrical connection	screw terminal (for 26 to 14 GA wire)
Housing	NEMA 1/IP20

†Rated Impulse Voltage 800V, Type of action 1, Control Pollution Degree 3.

Torque min. 45 in-lb for control of damper surfaces up to 11 sq ft.

Models

LMCB24-SR
LMCB24-SR-T

Application

For proportional modulation of dampers in HVAC systems. Actuator sizing should be done in accordance with the damper manufacturer's specifications.

The actuator is mounted directly to a damper shaft from 1/4" up to 5/8" in diameter by means of its universal clamp. Shafts up to 3/4" diameter can be accommodated by an accessory clamp.

The actuator operates in response to a 2 to 10 VDC, or with the addition of a 500 Ω resistor, a 4 to 20 mA control input from an electronic controller or positioner. A 2 to 10 VDC feedback signal is provided for position indication or master-slave applications.

Operation

The actuator is not provided with and does not require any limit switches, but is electronically protected against overload. The anti-rotation strap supplied with the actuator will prevent lateral movement.

The LMB series provides 95° of rotation and a visual indicator indicates position of the actuator. When reaching the damper or actuator end position, the actuator automatically stops. The gears can be manually disengaged with a button on the actuator cover.

The LMCB24-SR... actuators use a sensorless brushless DC motor, which is controlled by an Application Specific Integrated Circuit (ASIC). The ASIC monitors and controls the actuator's rotation and provides a digital rotation sensing (DRS) function to prevent damage to the actuator in a stall condition. Power consumption is reduced in holding mode.

Add-on auxiliary switches or feedback potentiometers are easily fastened directly onto the actuator body for signaling and switching functions.

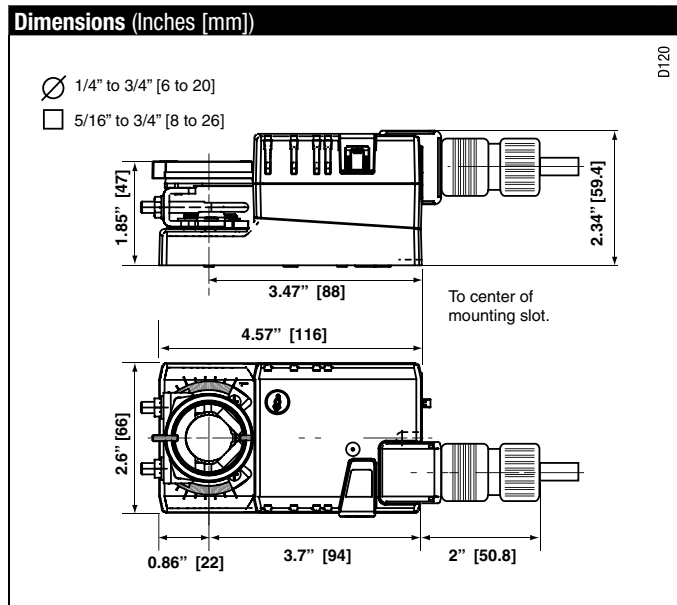

IM40024 - 05/10 - Subject to change. © Belimo Aircontrols (USA), Inc.

Accessories

K-LM20	3/4" [20 mm] Shaft Clamp
AV6-20	Shaft Extension
ZG-LMSA	Shaft Adaptor for 1/2" Diameter Shafts
ZG-LMSA-1	Shaft Adaptor for 3/8" Diameter Shafts
ZS-T	Terminal Cover for NEMA 2
ZS-100	Weather Shield - Steel
ZS-150	Weather Shield - Polycarbonate
Tool-06	8 mm & 10 mm Wrench
S1A, S2A	Auxiliary Switch(es)
P370	Shaft Mount Auxiliary Switch
P...A	Feedback Potentiometers
SGA24	Min positioners in NEMA 4 housing
SGF24	Min positioners for flush panel mounting
PTA-250	Pulse Width Modulation Interface
IRM-100	Input Rescaling Module
ADS-100	Analog to Digital Switch
ZG-R01	Resistor for 4 to 20 mA Conversion
NSV24 US	Battery Back-Up Module
ZG-X40	Transformer

NOTE: When using LMCB24-SR... actuators, only use accessories listed on this page.

Typical Specification

Proportional control damper actuators shall be electronic direct-coupled type, which require no crank arm and linkage and be capable of direct mounting to a shaft from 1/4" to 5/8". Shafts up to 3/4" diameter can be accommodate with an accessory clamp. Actuators must provide proportional damper control in response to a 2 to 10 VDC or, with the addition of a 500 Ω resistor, a 4 to 20 mA control input from an electronic controller or positioner. Actuators shall have brushless DC motor technology and be protected from overload at all angles of rotation. Actuators shall have reversing switch and manual override on the cover. If required, actuator will be provided with screw terminal strip for electrical connections (LMCB24-SR-T). Run time shall be constant and independent of torque. A 2 to 10 VDC feedback signal shall be provided for position indication. Actuators shall be cULus listed, have a 5-year warranty, and be manufactured under ISO 9001 International Quality Control Standards. Actuators shall be as manufactured by Belimo.

Wiring Diagrams

✂️ INSTALLATION NOTES

- 1 Provide overload protection and disconnect as required.
- 2 **CAUTION Equipment Damage!**
Actuators may be connected in parallel. Power consumption and input impedance must be observed.
- 3 Actuators may also be powered by 24 VDC.
- 5 Only connect common to neg. (-) leg of control circuits.

📄 APPLICATION NOTES

- ◆ The ZG-R01 500 Ω resistor converts the 4 to 20 mA control signal to 2 to 10 VDC, up to 2 actuators may be connected in parallel.

⚠️ WARNING Live Electrical Components!

During installation, testing, servicing and troubleshooting of this product, it may be necessary to work with live electrical components. Have a qualified licensed electrician or other individual who has been properly trained in handling live electrical components perform these tasks. Failure to follow all electrical safety precautions when exposed to live electrical components could result in death or serious injury.

